

iF0500N Ice Cube Machine

Models

- IDF0500N IYF0500N



Indigo NXT Series iF0500N Ice Machine on D570 Bin
*Ice machine and Bin sold separately

Designed for operators who know that ice is critical to their business, the Indigo NXT Series ice machine's preventative diagnostics continually monitor itself for reliable ice production. Improvements in cleanability and programmability make your ice machine easy to own and less expensive to operate.

- **New levels of Performance** – Showcasing an average of 12% lower energy consumption and a 23% reduction in condenser water usage. This translates into lower cost of ownership over the life of your machine.
- **easyTouch[®] Display** - New icon based touch screen takes the guess work out of owning and operating an ice machine.
- **Programmable Ice Production** – Now its super easy to program your ice machine to be off at certain times of the day to save money with fluctuating electrical rates. Also programmable by daily ice production volume and night time programming.
- **Easy to Clean Foodzone** – Hinge front door swing out for easy access. Removable water-trough, distribution tube, curtain, water probe and water pump for fast and efficient cleaning. Selected components are made with AlphaSan[®] antimicrobial.
- **Intelligent Diagnostics** – Provides 24 hour preventative maintenance and diagnostic feedback for trouble free operation.
- **Acoustical Ice Sensing Probe** – Unique patented technology allows for reliable operation in challenging water conditions and environments
- **DuraTech[®] Exterior** – Provides superior corrosion resistant above stainless steel. Innovative clear-coat resists fingerprints and dirt making it easier to keep clean.
- Available **LuminIce[®] II Virus and Bacteria Inhibitor** – Controls viruses, bacteria, mold and yeast within the food zone to keep the ice machine clean longer. A new sanitation icon lets you know the operational status.
- **Active Sense** – Insures consistent ice harvest in all environmental conditions. This software solution works in conjunction with the acoustical ice sensing probe improving reliability and performance.

Ice Machine Electric

115/60/1 standard
(208-230/60/1 also available)

Minimum circuit ampacity:

Remote 115v : 14.8

Maximum fuse size:

Remote 20 amps



Specifications

BTU Per Hour:
3,800 (average),
and 6,000 (peak)

Refrigerant:
R404A CFS - Free

Operating Limits:

- Ambient Temperature Range: 40 to 110 F (4.4 to 43.3 C)
Water Temperature Range: 40 to 90 F (4.4 to 32.2 C)
- Potable Water Pressure: Min. 20 psi (137.9 kPa)
Max. 80 psi (551.1 kPa)
- Condenser Water Pressure: Min. 20 psi (137.9 kPa)
Max. 276 psi (551.1 kPa)

Ice Shape



Half Dice
3/8" x 1 1/8" x 7/8"
(.95 x 2.86 x 2.22 cm)



Dice
7/8" x 7/8" x 7/8"
(2.22 x 2.22 x 2.22 cm)



iF0500N on D-570 Storage Bin

- Ⓐ Electrical Entrance (2) Options
- Ⓑ 3/8" (0.95 cm) F.P.T. Water Condenser Inlet (water-cooled units)
- Ⓒ 1/2" (1.27 cm) F.P.T. Water Condenser Outlet (water-cooled units)
- Ⓓ 1/2" (1.27 cm) Auxiliary Base Drain Socket
- Ⓔ 3/8" (0.95 cm) F.P.T. Ice Making Water Inlet
- Ⓕ 1/2" (1.27 cm) F.P.T. Ice Making Water Drain
- Ⓖ 3/4" (1.91 cm) Bin Drain

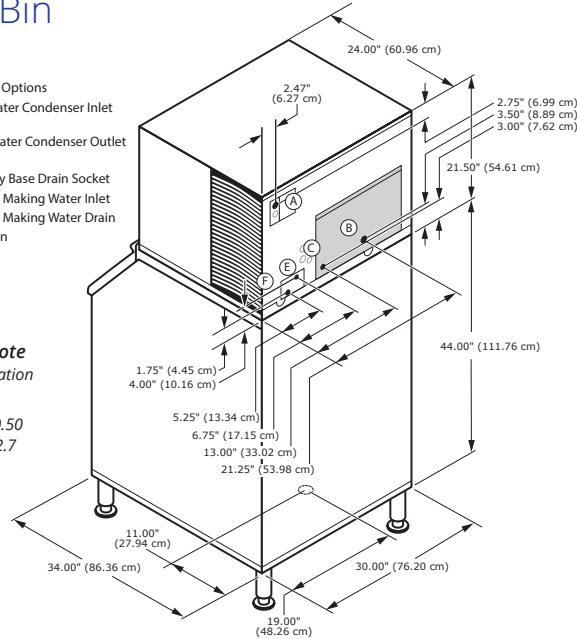

Installation Note

Minimum installation clearance:
 Top/side: 12" (30.50 cm)
 Back is 5" (12.7 cm)

Space-Saving Design



	iF0500N D-400	iF0500N D-570
Height	59.50" 151.13 cm	71.50" 181.61 cm
Width	30.00" 76.2 cm	30.00" 76.2 cm
Depth	34.00" 86.30 cm	34.00" 86.30 cm
Bin	365 lbs.	532 lbs.
Storage	165.7 kgs.	241.1 kgs.

Height includes adjustable bin legs 6.00" to 8.00", (15.24 to 20.32 cm) set at 6.00" (15.24 cm).
 Bin capacity is based on 90% of the volume x 33 lbs/ft³ average density of ice.

Specifications

	Model	Ice Shape	Ice Production 24 Hours		Power Usage kWh/100 lbs. @90°Air/70°F 1 Ph	Potable Water Usage/100 lbs. 45.4 kgs. of Ice
			70°Air/ 50°F Water	90°Air/ 70°F Water		
REMOTE COOLED	IDF0500N	dice 	510 lbs.	445 lbs.	5.96	19 Gal.
			231 kgs	202 kgs		71.9 L
	IYF0500N	half-dice 	525 lbs.	465 lbs.	6.0	19 Gal.
			238 kgs	211 kgs		71.9 L

* Ice storage bin and JCF0500 remote condenser for remote units must be order separately

Standard Remote Tubing Kits

Tubing Kit	Tubing Length
RT20R404	20 ft / 6.1 m
RT35R404	35 ft / 10.7 m
RT50R404	50 ft / 15.2

Remote Ambient Operating Temperature: -20 to 120F (-29C to 49C)



Standard air-cooled remote JCF0500-161

Accessories

LuminIce® II Virus and Bacteria Inhibitor

controls viruses and bacteria in the ice machine.



External Scoop holder

Protect the ice scoop with the NSF approved versatile scoop holder.



Arctic Pure® Water Filters

Reduces sediment and chlorine odors for better tasting ice.



iAuCS®

schedules and performs routine ice machine cleaning automatically.



Welbilt reserves the right to make changes to the design or specifications without prior notice.